



**GENERALITIES** The present rider forms an integral part of the contract between the Producer and the Presenter. The Presenter agrees to provide all of the material described in this document and to respect all of this rider's clauses. In the event that the Presenter cannot provide the material required by the Producer, he or she must advise the Producer as soon as possible.

**ARTISTS** AUDRÉE ALEXANDRINE, SOPRANO - CLARA.  
RICHARD-NICOLAS VILLENEUVE, TENOR - NUTCRACKER AND KING OF RATS  
EMMANUELLE DA SILVA, FLÛTE, CLARINET, SAXOPHONE - SUGAR PLUM FAIRY  
XAVIER ROUSSEAU, PIANO - UNCLE DROSSELMAYER

**ARRIVAL** SCHOOLS: 75 MINUTES BEFORE THE CONCERT / PERFORMANCE HALLS: 90 MINUTES BEFORE THE CONCERT

**SETTING UP** 60 MINUTES (SET ASSEMBLED BY THE MUSICIANS)

**CONCERT DURATION** 55 MINUTES (6 TO 12 YEARS OLD VERSION) OR 35 MINUTES (3 TO 5 YEARS OLD VERSION)

**TEARING DOWN** 60 MINUTES (SETS STRUCK BY THE ARTISTS)

**REQUIRED STAFF** 1 TECHNICIAN TO ANSWER ARTISTS' QUESTIONS AND NEEDS AND FOR THE STAGE LIGHTING SET UP

**EQUIPEMENT PROVIDED BY THE CLIENT** 1 **GRAND PIANO** TUNED UP THE DAY BEFORE THE CONCERT  
\*Note : An electric piano can be provided by the JMC, if asked by the client.  
The staging is unfortunately impossible to create with an upright piano  
2 **REGULAR POWER OUTLETS**  
1 **POWER EXTENSION CORD** WITH TWO INPUTS (FOR THE ELECTRIC PIANO AND THE SMALL SPEAKERS)

**STAGE** WIDTH: 22' DEPTH: 12' HEIGHT: 9' SEE FULL STAGE LAYOUT ON PAGE 2  
STAGE MUST BE CLEAN AND FREE FROM ALL OBSTACLE UPON ARRIVAL OF THE ARTIST  
IF THERE IS NO STAGE, PLEASE HAVE THE CHILDREN SIT ON MATTRESSES INSTEAD OF CHAIRS TO ALLOW THEM TO SEE ACTION ON THE GROUND.  
PLEASE LEAVE 4' BETWEEN THE STAGE AND THE PUBLIC

**LIGHTINGS** \*THIS CONCERT CAN BE PRESENTED IN NATURAL DAYLIGHT OR WITH REGULAR CEILING LIGHTS, IF THE SPACE IS NOT EQUIPPED.

PERFORMANCE HALLS: COMPLETE LIGHTING PLAN PROVIDED UPON REQUEST

NOTE 1: HOUSE LIGHTS AT 15% DURING THE ENTIRE DURATION OF THE CONCERT TO ALLOW THE MUSICIANS TO SEE THE CHILDREN  
NOTE 2: RAISE HOUSE LIGHTS TO 50% WHEN MUSICIANS MAKES THEIR WAY INTO THE AUDIENCE.

**SOUND** \*THIS CONCERT IS PERFORMED WITHOUT AMPLIFICATION WHEN HALL ACOUSTICS ALLOW.

IN LARGE VENUES, CHURCHES, OUTDOOR STAGES AND ANY PLACES WHERE AMPLIFICATION IS NEEDED, THE BUYER MUST PROVIDE:

- 2 TO 4 MICROPHONES WITH STANDS SET UP IN FRONT OF THE STAGE OR HUNG UP, TO CAPTURE EVERY SOUND
- PIANO AMPLIFICATION, IF NECESSARY.

**DRESSING ROOMS** 1 OR 2 PRIVATE DRESSING ROOMS TO WELCOME 4 ARTISTS

**PARKING** 1 PARKING SPACE FOR THE ARTIST, NEAR THE STAGE.

**CONTACT** HEAD ARTIST: Xavier Rousseau, 514-432-3316 or [xavier\\_rouss@hotmail.com](mailto:xavier_rouss@hotmail.com)

**NOTE** It is strictly forbidden to record the performance or to take photos during the show. Musicians will be happy to take time for photos afterwards.

Parties Initials:

\_\_\_\_\_ JMC

\_\_\_\_\_ Buyer

**INFORMATION**

Montreal performance halls: Judith Pelletier, 514-845-4108, ext. 230; [jpelletier@jmcanada.ca](mailto:jpelletier@jmcanada.ca)  
Schools and performance halls: André Mercier, 514-845-4108, ext. 221; [amercier@jmcanada.ca](mailto:amercier@jmcanada.ca)  
Pictures, promotional video, illustration and teaching guide available at [www.jmcanada.ca](http://www.jmcanada.ca)



STAGE LAYOUT

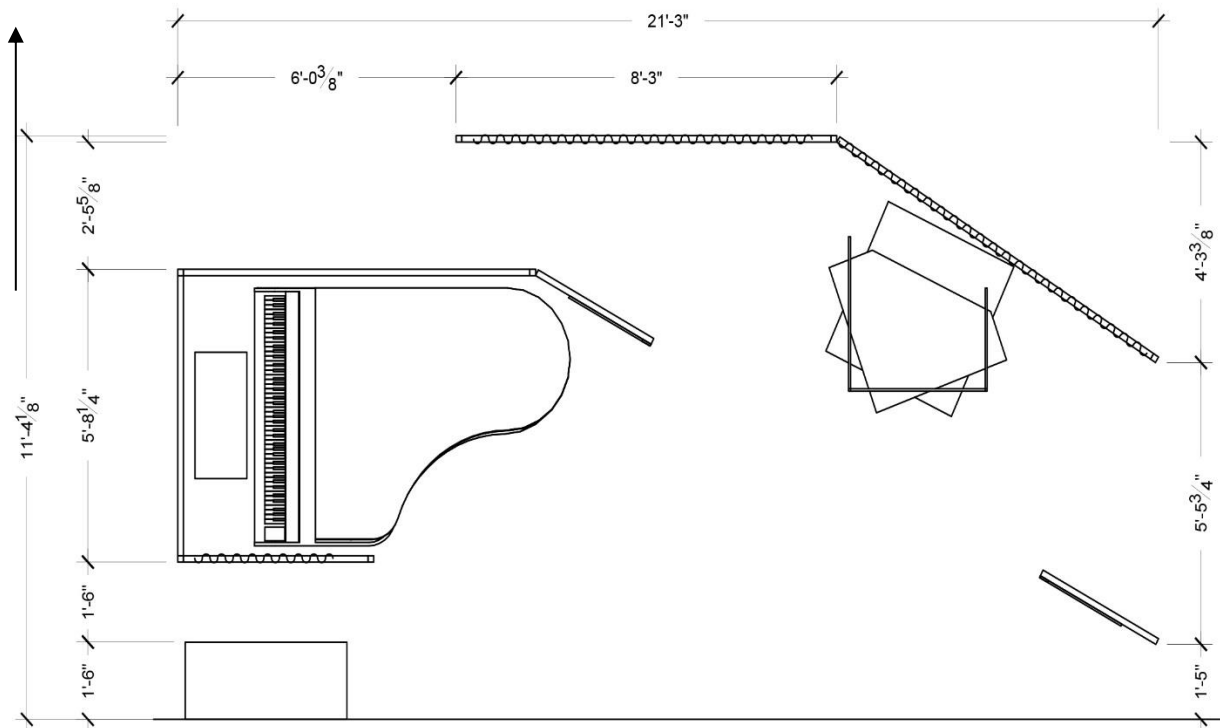

ESPACE SCÉNIQUE MINIMUM :  
21'-3" DE LARGE PAR 11'-5" DE PROFOND



Parties Initiales

JMC

Buyer

INFORMATION

Montreal performance halls: Judith Pelletier, 514-845-4108, ext. 230; [jpelletier@jmcanada.ca](mailto:jpelletier@jmcanada.ca)  
Schools and performance halls: André Mercier, 514-845-4108, ext. 221; [amercier@jmcanada.ca](mailto:amercier@jmcanada.ca)  
Pictures, promotional video, illustration and teaching guide available at [www.jmcanada.ca](http://www.jmcanada.ca)